

Air injection Vacuum Blower

VT840.XL

Hibon Ingersoll Rand presents new state-of-the-art technology in three-lobe, positive displacement blowers. The VTB XL series air-injected, high-vacuum blowers offer a wide range of design features and incorporate energy efficiency improvements, complying with the strictest operational requirements of a variety of applications. These high-vacuum blowers are ideally suited for the rigorous demand of the vacuum truck market. Hibon is a worldwide leader in three-lobe positive displacement blower technology with thousands of units installed around the globe.

Characteristics

- Three-lobe impeller construction
 - Unique air injection system
 - Increased efficiency
 - Clearances adjusted automatically during assembly
 - Larger oil capacity
 - High volume oil thrower
 - High performance sealing arrangement using 4 piston rings
 - For Europe only, available in ATEX on request
- Ex II 2/2 G/D c, II BT3, 160° C X

Benefits

- Quieter operation than two-lobe impeller construction
- Allows high vacuum including "dead end" operation without overheating
- No oil or water cooling system (100% oil free air)
- Requires less horsepower for the same performance
- Easier maintenance
- Runs cooler
- Better lubrication of bearings
- Less frequent oil changes

Configurations

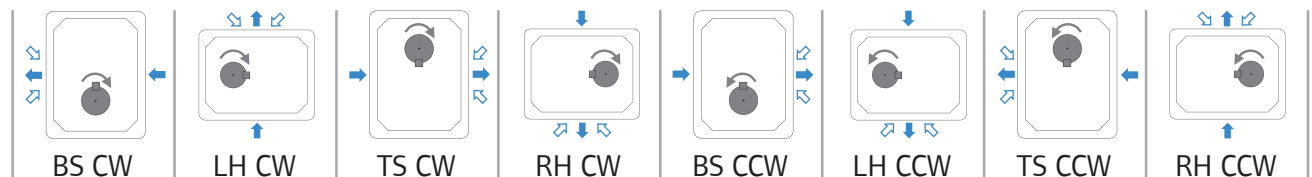

Better by design

Configuration	With feet option	Without feet option
BS CW	.	F0175701111
LH CW	.	F0175701011
TS CW	.	F0175701211
RH CW	.	F0175701311
BS CCW	.	F0175701101
LH CCW	.	F0175701001
TS CCW	.	F0175701201
RH CCW	.	F0175701301

- ↻ Shaft rotation
- ➡ Air flow
- ⇄ Air injection
- RH = Right hand shaft
- LH = Left hand shaft
- BS = Bottom shaft
- TS = Top shaft
- CW = Clockwise rotation
- CCW = Counter clockwise rotation

Performances chart

VOLUME DISPLACEMENT (6492 m³/h)																
Feet (tr/min)	30% Vacuum		40% Vacuum		50% Vacuum		60% Vacuum		70% Vacuum		80% Vacuum		90% Vacuum		93% Vacuum	
RPM	m³/h	kW	m³/h	kW	m³/h	kW	m³/h	kW	m³/h	kW	m³/h	kW	m³/h	kW	m³/h	kW
1000	2174	24	2057	31	1905	38	1680	45.9	1310	53	628	61	-	-		
1200	2704	28	2590	37	2442	46	2223	55,1	1862	64	1197	73	-	-		
1400	3234	33	3124	43	2979	53	2766	64,2	2414	75	1767	86	301	93,3		
1600	3764	38	3657	49	3516	61	3308	73,4	2966	86	2336	98	909	110		
1800	4294	42	4190	55	4053	69	3851	82,6	3518	96	2905	110	1518	124		
2000	4824	47	4723	61	4590	76	4393	91,8	4070	107	3475	122	2126	138		
2200	5354	52	4256	67	5127	84	4936	101	4622	118	4044	135	2735	151		
2400	5884	57	5789	73	5664	92	5479	110	5174	128	4613	147	3344	165		
2600	6375	61	6301	79	6188	99	6021	119	5711	139	5155	159	-	-	BO	185

* Volume displacement at maximum speed. - BO = Blanked off

VTB 840.XL Dimensions

BS CCW Configuration Vertical gears

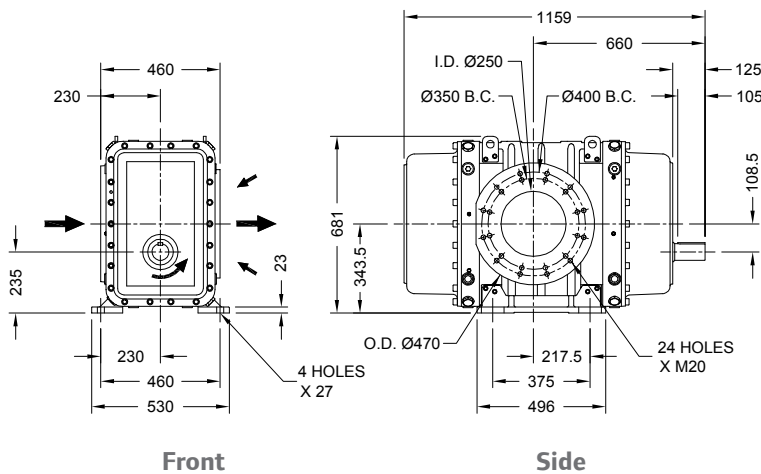

Shaft details

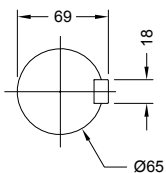

Discharge Flange

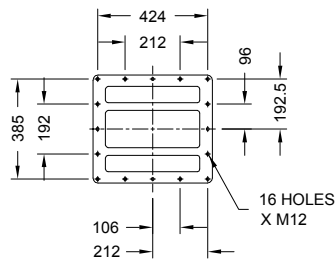

Notes:

1. English units (mm)
2. Weight: 775 Kg
3. Other configurations also available on request.
4. Do not use for construction
5. TROUS = HOLES

LH CCW Configuration Horizontal gears

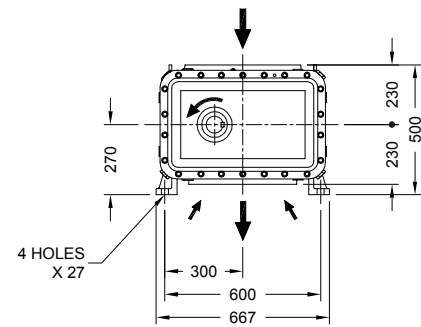

FRONT
Front

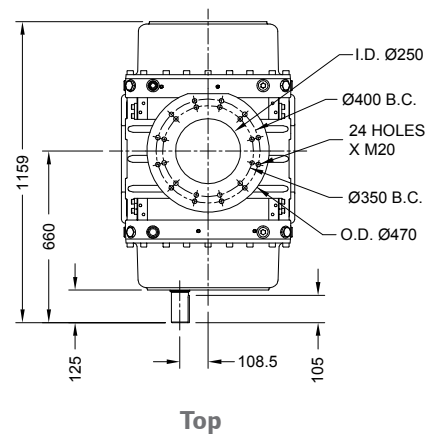

Top

Spare parts and accessories

Kit 1 - STANDARD MAINTENANCE KIT	Kit 2 - SET OF RING HOLDERS	Kit 3 - SET OF GEARS	MANIFOLD AND DISCHARGE/INJECTION MANIFOLD GASKETS	HIBON LUBE 2 liters or 5 liters
Contains all parts required for 40 000 h. maintenance				

For more information about spares and accessories, contact your nearest Service Center or Ingersoll Rand - HIBON company.

Compressed Air Systems and Services
Hibon Inc
100 Voyageur Pointe Claire, Quebec
Canada, H9R 6A8
Tel: 514 631-3501
Fax: 877 584 0307
www.hibon.com www.ingersollrand.com

Ingersoll Rand (NYSE:IR) advances the quality of life by creating comfortable, sustainable and efficient environments. Our people and our family of brands—including Club Car®, Ingersoll Rand®, Thermo King® and Trane®—work together to enhance the quality and comfort of air in homes and buildings; transport and protect food and perishables; and increase industrial productivity and efficiency. We are a \$13 billion global business committed to a world of sustainable progress and enduring results.

ingersollrandproducts.com
We are committed to using environmentally conscious print practices

Ingersoll Rand Air Solutions Hibon®
2 avenue Jean-Paul Sartre, 59290 WASQUEHAL France
Tel: +33 (0)3 20 45 39 39
Fax: +33 (0)3 20 45 39 20 (Fax Service)
www.hibon.com www.ingersollrand.com
email : hibon@irco.com



©2017 Ingersoll-Rand Company